

8Z6101PS

(ON 0NIMVHO)台架図

△ φ10MAX CABLE ENTRY
使用ケーブル最大径φ10

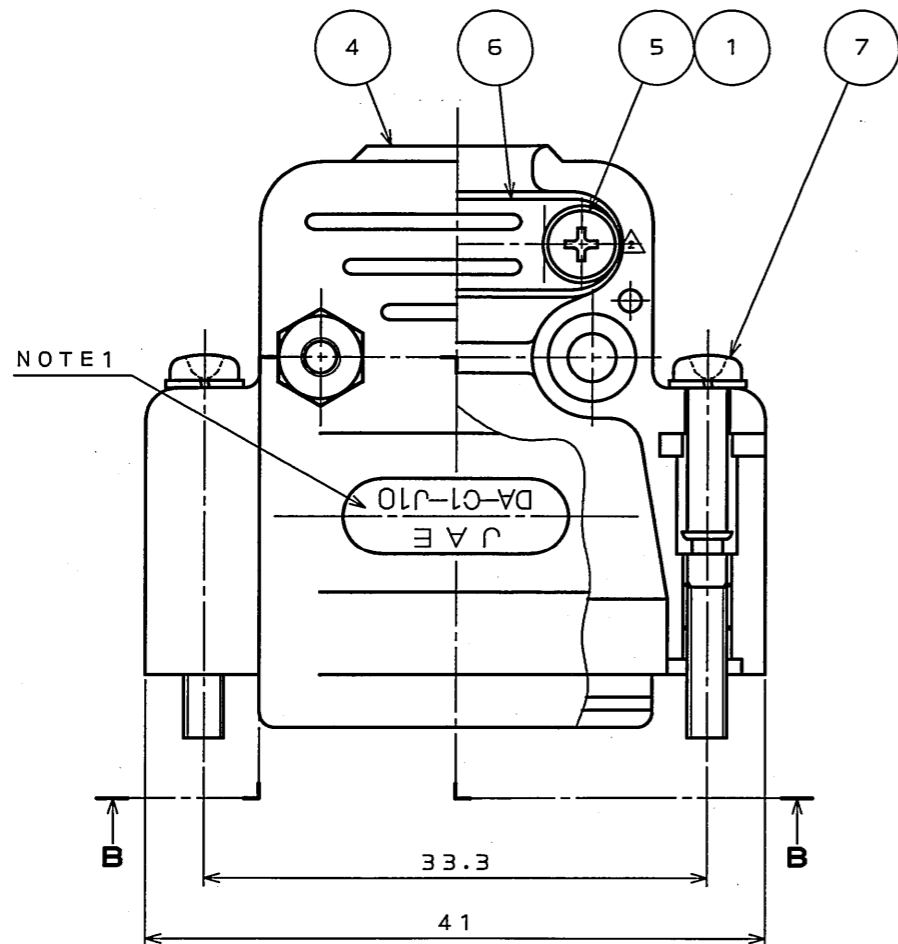
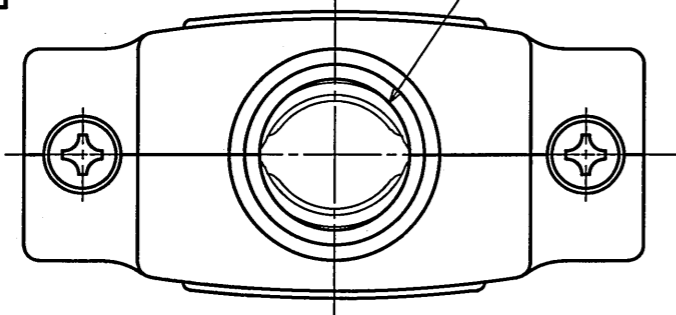

NOTE 1

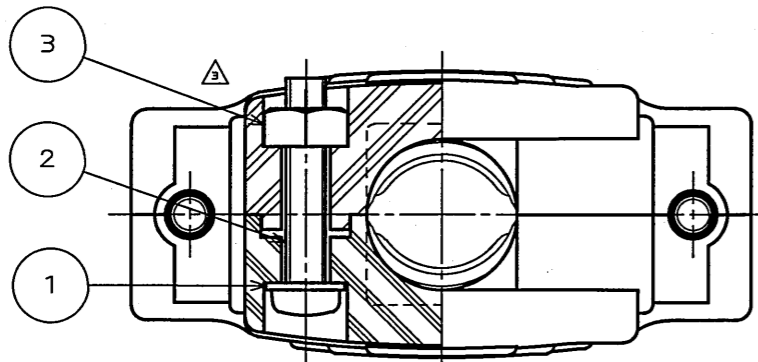

SECT. B-B △

△ NOTE 1. LETTERS "JAE" AND "DA-C1-J10" ARE SHOWN ON THIS SURFACE.
2. PARTS SHALL BE SUPPLIED BEFORE ASSEMBLY.

注1. 図示の位置に "JAE" "DA-C1-J10" を表示する。
注2. 各部品は組立せず、ばらの状態で納入する。

版数 REV.	年月日 DATE	DCN NO.	変更内容 DESCRIPTION	製図 DR.	担当 CHK.	査閲 APPD.	承認 APPD.
2	25.Aug.2005	058072	SCREW REVISED FORM OTHERS		Y.TAKAGI		Y.KUBOTA
3	10.Apr.2006	059841	CORRECT AN ERROR		Y.TAKAGI	A. Tago	J. Kubota

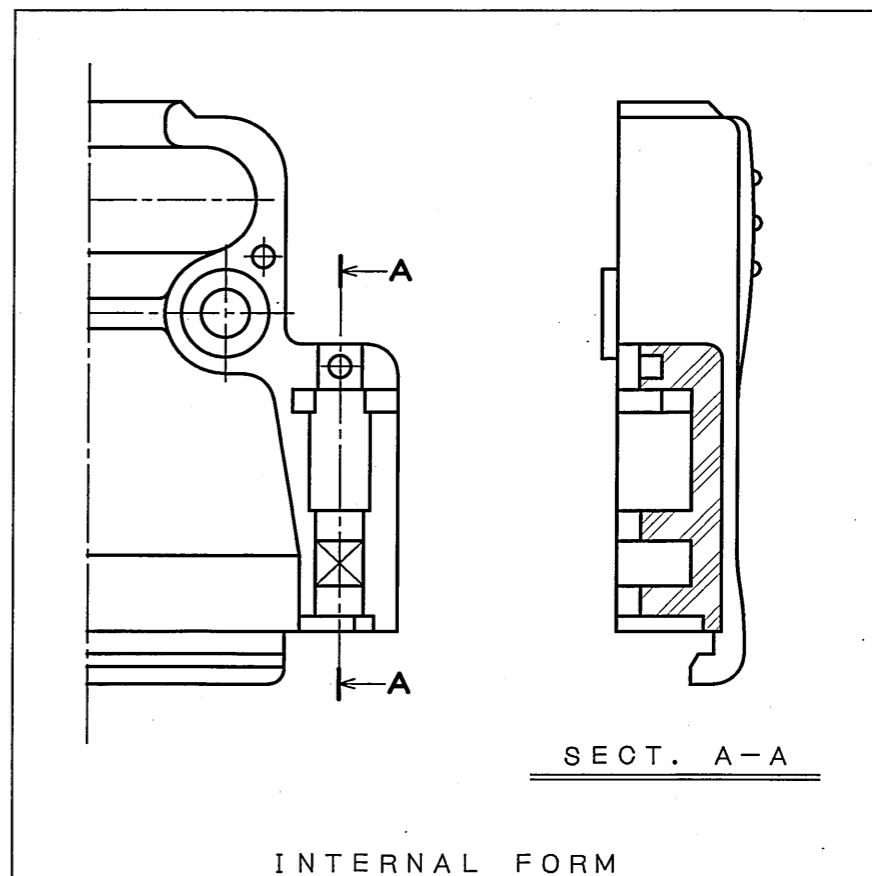
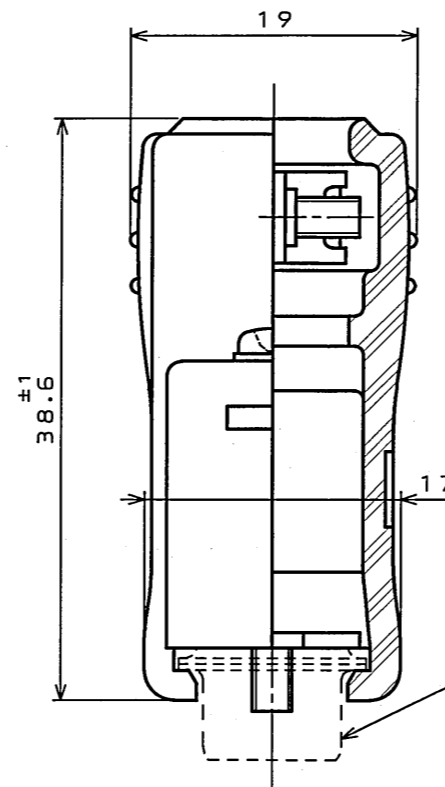

INTERNAL FORM
内部形状

符号 NO.	名称 DESCRIPTION	個数 QTY.	材料 MATERIAL	仕上 FINISH	備考 REMARKS
7	SCREW LOCK ASS'Y	2	STEEL	HEXAVALENT CHROMIUM FREE CHROMATE (TRIVALENT CHROMATE TREATMENT) ON ELECTROPLATED ZINC	M2.6
	SPRING WASHER	2	STEEL	HEXAVALENT CHROMIUM FREE CHROMATE (TRIVALENT CHROMATE TREATMENT) ON ELECTROPLATED ZINC	
6	CLAMP SADDLE	2	STEEL	HEXAVALENT CHROMIUM FREE CHROMATE (TRIVALENT CHROMATE TREATMENT) ON ELECTROPLATED ZINC	
△ 5	CROSS PAN HEAD SCREW	2	STEEL	HEXAVALENT CHROMIUM FREE CHROMATE (TRIVALENT CHROMATE TREATMENT) ON ELECTROPLATED ZINC	M2.6×7
4	HOOD	2	ABS RESIN	(COLOR: LIGHT GREY)	
3	HEXAGON NUT	2	COPPER ALLOY △	HEXAVALENT CHROMIUM FREE CHROMATE (TRIVALENT CHROMATE TREATMENT) ON ELECTROPLATED ZINC	M2.6
△ 2	CROSS PAN HEAD SCREW	2	STEEL	HEXAVALENT CHROMIUM FREE CHROMATE (TRIVALENT CHROMATE TREATMENT) ON ELECTROPLATED ZINC	M2.6×14
1	SPRING WASHER	4	STEEL	HEXAVALENT CHROMIUM FREE CHROMATE (TRIVALENT CHROMATE TREATMENT) ON ELECTROPLATED ZINC	M2.6

仕様書 (SPECIFICATION)	第1版 (ORIGINAL DATE) 16.May.2005	尺度 (SCALE) 2:1	シリーズ (SERIES) D-sub	日本航空電子工業株式会社 JAPAN AVIATION ELECTRONICS INDUSTRY, LTD.
製図 DR.	担当 CHK. T.NOMIYAMA	名称 (TITLE) DA-C1-J10R		
査閲 APPD.	承認 APPD. Y.KUBOTA	図面番号 (DRAWING NO.) SJ101928		
版数 (REV.)	3	質量 (MASS)		

DOF-0-212E(03.08)

